

REV	DESCRIPTION	SIGN	DATE
1		IVAN	01/10'17

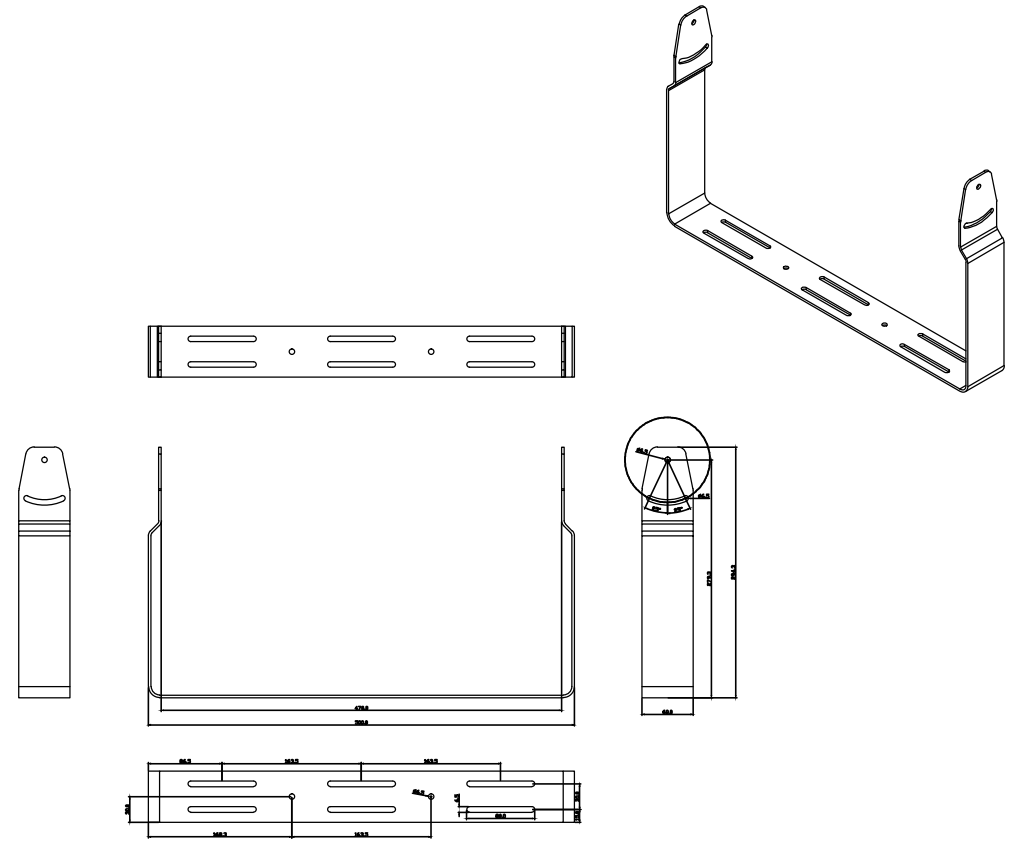

髮線方向(雙面)

NOTES:
 請去除銳角及毛邊.
 表面處理後,孔徑大小需照圖面標示.
 表面處理後,注意攻牙內孔及有效牙深.
 髮線為#200

TOL	< 30	: ±0.1	UNIT : mm	FINISHING	PART NO.	411381910401	Ver.	1				
	30 < 120	: ±0.15				MOLD NO.	VITAM-819P	Q'ty	1			
	120 < 315	: ±0.2	3RD ANGLE'S	MATERIAL	SUS304 T=3.0	TITLE						
	315 <	: ±0.3		APPROVED	JASON	01/10'17	YOKE MOUNT					
ANGLE TOL		: ±0.5°	CHECKED	CLARK	01/10'17	DRAWING NO.						
APLEX Technology Inc. 維田科技股份有限公司				DESIGNED	IVAN	01/10'17	SIZE	A4	SCALE	1:1	SHEET	1 OF 1